

SHARK® 100-S

SHARK® 200-S

ELECTRONIC SUBMETERS WITH WIFI ETHERNET CAPABILITY



**EXTENSIVE
DATA-LOGGING**
Shark® 200-S Meter

NEW

INDUSTRY LEADING TECHNOLOGY

- High Performance Metering Technology
- 0.2% Accuracy Class — Highly Accurate
- Revenue Certifiable Test Pulse with KYZ Output
- IEEE 802.11 Wireless Ethernet Capability
- 10/100BaseT Ethernet - RJ45
- Modbus RS485 or Modbus TCP
- For Commercial Building, Industrial and Shopping Mall Applications
- 2 Megabytes Flash Memory for Extensive Datalogging (Shark® 200-S Submeter)

Shark® 100-S
Economical WiFi
Submeter

Real Time
Monitoring Only



Shark® 200-S
Advanced Datalogging
WiFi Submeter

Onboard Logging,
Automated Billing

www.electroind.com



Electro Industries/GaugeTech
The Leader in Power Monitoring and Smart Grid Solutions



Feature Summary

- 0.2% Class Revenue Certifiable Energy and Demand Submeter
- Meets ANSI C12.20 (0.2%) and IEC 687 (0.2%) Classes
- Multifunction Measurement Capability
- Bright Red LED Display with three .56" lines
- % of Load Bar for Analog Meter Perception
- Ethernet or Wireless Ethernet (Modbus TCP)
- Serial RS485 Communication (Modbus RTU/ASCII)
- Direct Interface with Most Building Management Systems
- Very Easy To Install
- Extensive Datalogging and Alarm Recording
(Shark® 200-S Submeter)



**Highly Accurate Metering,
Simple Communication Technology**



Applications

- Universities
- Commercial Buildings
- Shopping Malls
- Airports
- Industrial Submetering
- Government Facilities
- Military
- Energy Efficiency OEMs

Introduction

Electro Industries introduces the most advanced series of electrical submeters available. These high performance products measure revenue grade electrical energy usage and communicate back information using RS485, RJ45 Ethernet or IEEE 802.11 WiFi Ethernet connections. Place a unit anywhere within a facility and it can communicate back to central software quickly and automatically.

The units use standard 5 or 1 amp CTs (either split or donut). They surface mount to any wall and are easily programmed in minutes.



Use Ethernet or WiFi to easily meter any facility

V-Switch™ Technology Measurement Upgrade Packs

The Shark® 100-S/200-S submeters are equipped with EIG's exclusive V-Switch™ technology, a virtual firmware-based switch that allows you to enable meter features through communication, even after installation. Using V-Switch™ keys, you can purchase what you require now and field upgrade functionality as needed. This allows you to optimize your metering investment. Begin with a simple energy billing submeter and upgrade it to a full functioning energy billing meter with power quality and alarm measurements.

Available V-Switches:

- V3 (100-S only) – Volts, Amps, kW, kVAR, PF, kVA, Freq. kWh, kVAh, kVARh
- V4 (100-S only) – Volts, Amps, kW, kVAR, PF, kVA, Freq. kWh, kVAh, kVARh, %THD Monitoring and Limit Exceeded Alarms
- V33 (200-S only) – Volts, Amps, kW, kVAR, PF, kVA, Freq. kWh, kVAh, kVARh, 2 Megabytes Datalogging memory and Limit Exceeded Alarms.

Note: The Shark® 200-S submeter does not have an upgrade for harmonic measurements.

Shark® Series Submeter Accuracy (Class 10)

| Measured Values | Accuracy |
|--------------------------|-----------------|
| Voltage L-N | 0.1% of Reading |
| Voltage L-L | 0.1% of Reading |
| Current | 0.1% of Reading |
| +/- Watts | 0.2% of Reading |
| +/- Wh | 0.2% of Reading |
| +/- VARs | 0.2% of Reading |
| +/- VARh | 0.2% of Reading |
| VA | 0.2% of Reading |
| VAh | 0.2% of Reading |
| PF | 0.2% of Reading |
| Frequency | 0.03Hz |
| %THD (Shark® 100-S only) | 5.0 % |
| Load Bar | +/- 1 Segment |

Generate Cost Allocation and Billing

Using Electro Industries' E-Billing EXT™ software, you can track energy usage data to provide utility bills for usage and demand. You can also customize rate structures and aggregate multiple meters for billing. E-Billing EXT™ produces bills utilizing either Energy Manager HMI logging or from data stored in Shark® 200-S logs. For simple bill generation we highly recommend using the Shark® 200-S submeter with internal logging.

- Lower demand cost
- Provide meter billing services
- Provide user accountability for actual usage

Traceable Watt-Hour Test Pulse for Accuracy Certification

To be certified for revenue metering, power providers and utility companies need to know that the billing energy meter will perform to its stated accuracy. To verify the meter's performance and calibration, power providers use field test standards to insure that the unit's energy measurements are correct. Since the Shark® 100-S/200-S submeters are traceable revenue meters, they contain a utility grade test pulse allowing power providers to verify and confirm that the meters are performing to their rated accuracy. This is an essential feature required of all billing grade meters.

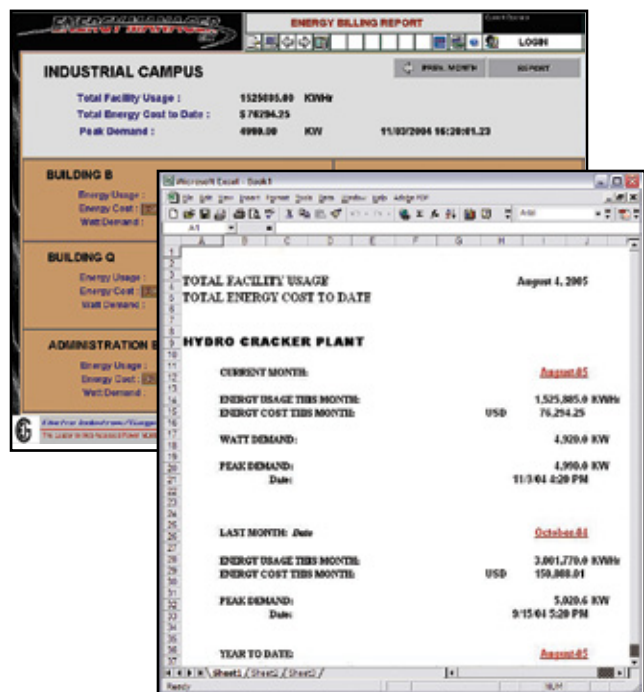

Utility Peak Demand Metering

The Shark® 100-S/200-S submeters provide user-configured Block Window or Rolling Window Demand. This allows you to set up a particular utility demand profile. Block Window Demand is demand used over a fixed user-configured demand period (usually 5, 15 or 30 minutes). Rolling Window Demand is a fixed window demand that moves for a user specified sub-interval period. An example is a 15-minute demand using 3 subintervals,

providing a new demand reading every 5 minutes based on the last 15 minutes. Readings for kW, kVAR, kVA and PF are calculated using utility demand structures. Other parameters offer max and min capability over the user-selectable averaging period. Voltage provides a non-rolling instantaneous max and min reading, displaying the highest surge and lowest sag seen by the meter.

Advanced Communication Capability with IrDA Interface

Standard Modbus RS485 Communication

Standard communication includes an RS485 output speaking Modbus protocol. This allows the unit to be connected to any serial RS485 bus using the Modbus interface. The unit communicates easily with most building automation or other software systems. Baud rates are up to 57.6K baud to provide fast update times.

WiFi or Land Based Ethernet

The unit offers two Ethernet options — either an RJ45 or WiFi connection. The WiFi option allows the 100-S/200-S submeter to be used on standard WiFi base stations. The unit is assigned an IP address; it communicates Modbus protocol over Ethernet TCP/IP.

IrDA Port

Use an IrDA-equipped laptop PC to program and read the Shark® 100-S/200-S submeter.



KYZ Pulse

For applications in which a pulse is needed, the unit also provides a KYZ output which pulses proportional to the amount of energy consumed. This feature is used for pulse counting applications or for building management systems where serial or Ethernet protocol is not available.

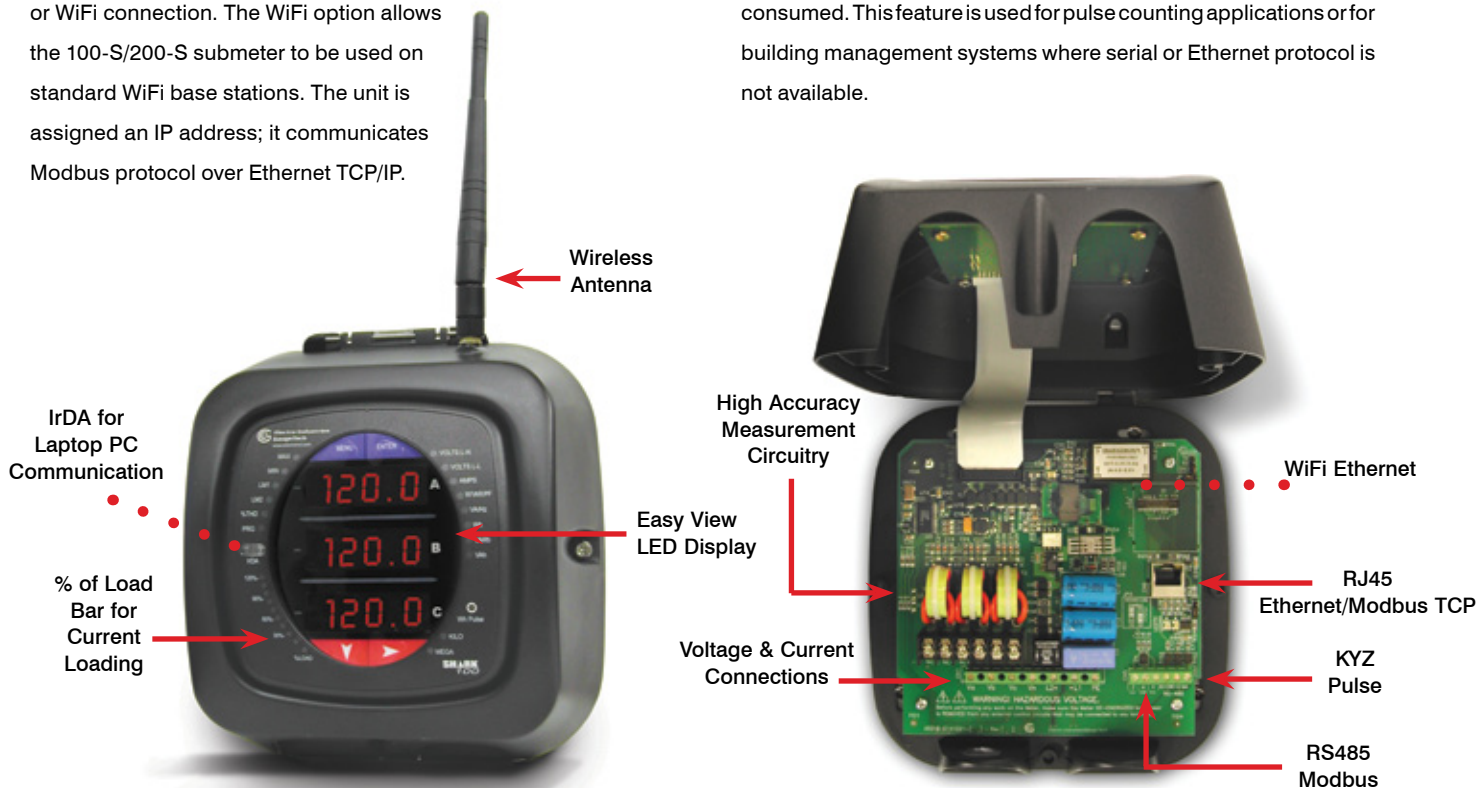

Superior Ethernet Simplifies Meter Connectivity

These submeters harness the latest Ethernet technology by providing a simple, over-the-counter wireless architecture. The submeter communicates over any existing wireless or wired Ethernet infrastructure. Just install the unit, plug in its IP address, and the device automatically connects to your LAN wirelessly. You can extend the network simply by adding WiFi access points. Wireless Ethernet is reliable and easy to integrate, making it the superior solution for mass meter deployment.

Benefits of Wireless Ethernet over Dedicated 900 MHz Spread Spectrum

- Standard Infrastructure (No Dedicated Hardware)
- Low Cost to Deploy and Expand
- Superior Speed Over Dedicated Wireless Networks
- Significantly Easier to Configure and Maintain
- Standard Modbus TCP Data Stream
- Can Be Easily Integrated Through the Internet

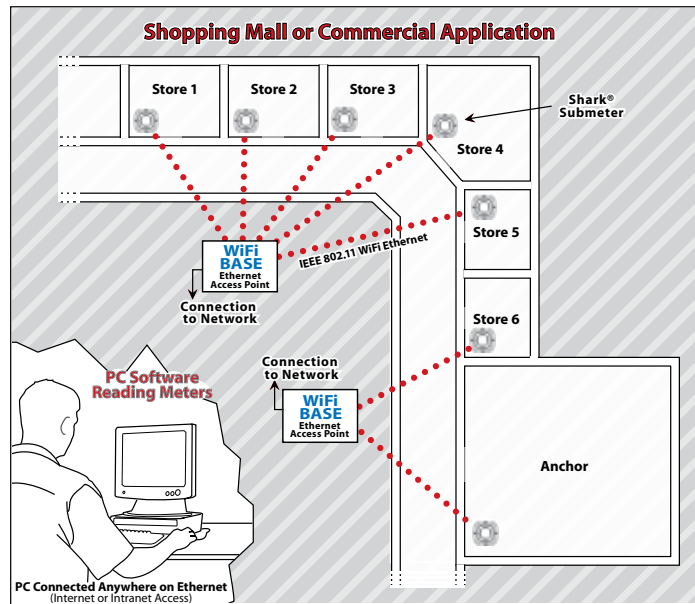

WiFi Ethernet — the simplest way to implement a fast, reliable metering project

Shark® 200-S Advanced Logging Features

Extensive Datalogging Capability

The Shark® 200-S submeter has 2 Megabytes of Flash memory that give it extensive datalogging capability. The 200-S offers three Historical logs, a Limits (Alarm) log, and a System Events log. The unit has a real-time clock that allows for time-stamping of all the data in the instrument when log events are created.

Historical logs:

Each of the three historical logs can be programmed with unique parameters consisting of any measured reading. Up to 64 parameters can be recorded per log.

Limits (Alarm) log:

The Limits log provides magnitude and duration of an event. 2048 events are available; the log provides time-stamp and alarm value.

System Events (anti-tampering) log:

To protect critical billing information, the meter records and logs the following with a time stamp:

- Demand/Energy/Log resets
- Password requests
- System startup
- Log reads
- Changes to meter's programmable settings



Historical Trending

The figure shows a screenshot of the Shark 200-S software interface displaying an 'Alarm Log' table. The table has columns for 'Date/Time', 'Value', and 'Unit'. It contains multiple rows of alarm events, including 'Demand/Energy/Log resets', 'Password requests', 'System startup', 'Log reads', and 'Changes to meter's programmable settings'.

Alarm Log

Dimensional Drawings

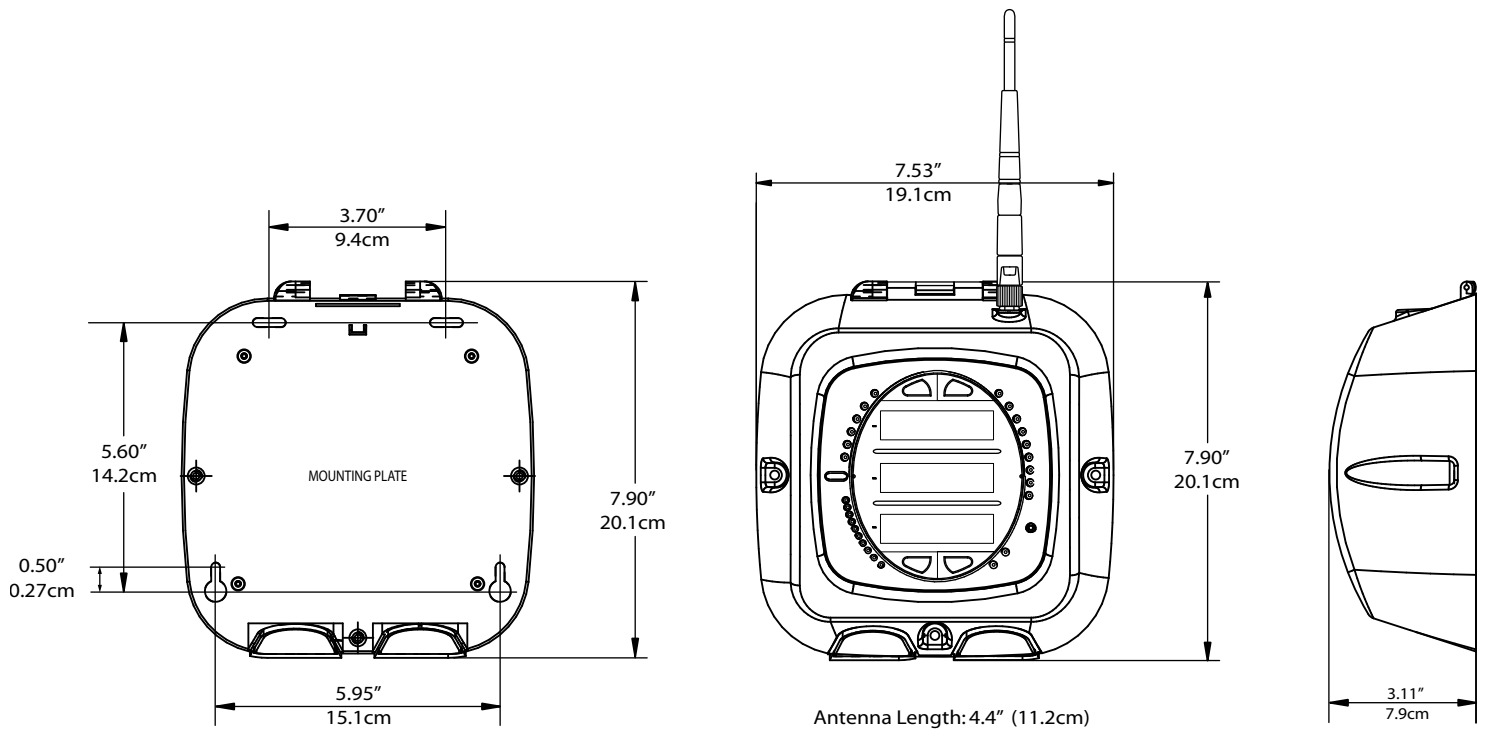

Installation

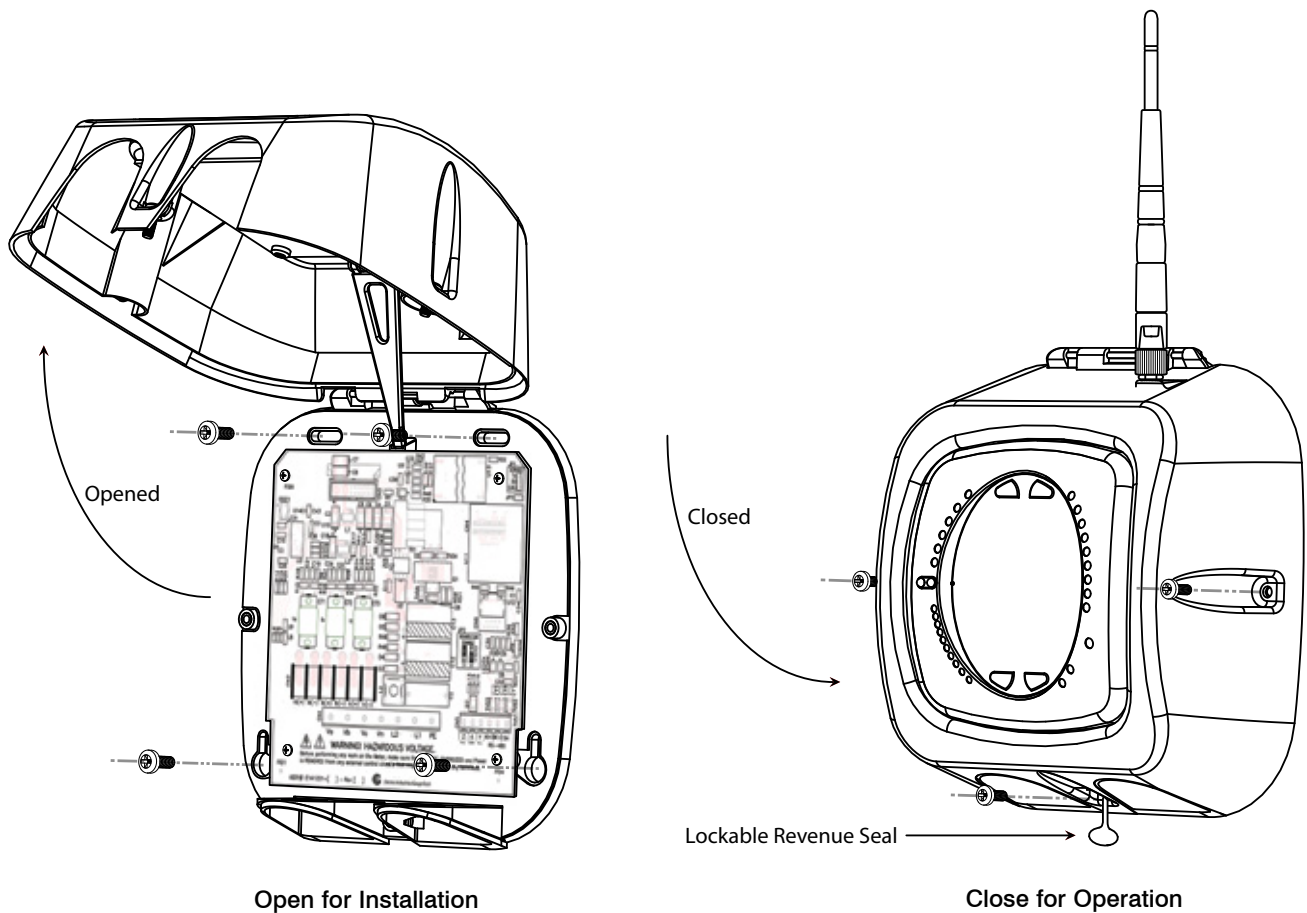

Wiring Diagrams

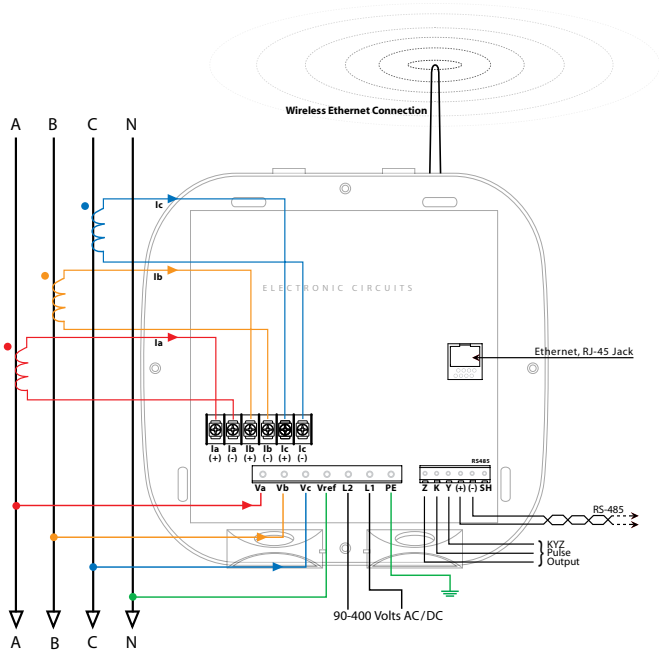

3 Phase 4 Wire WYE Direct

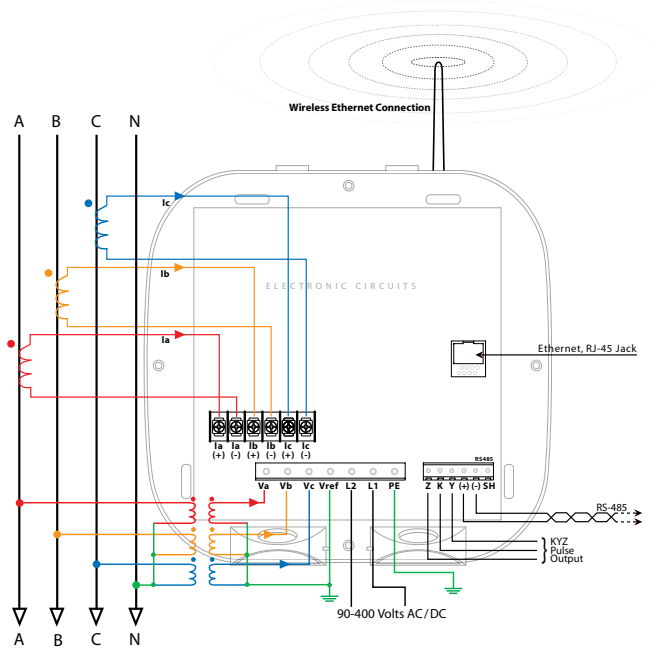

3 Phase 4 Wire WYE with PTS

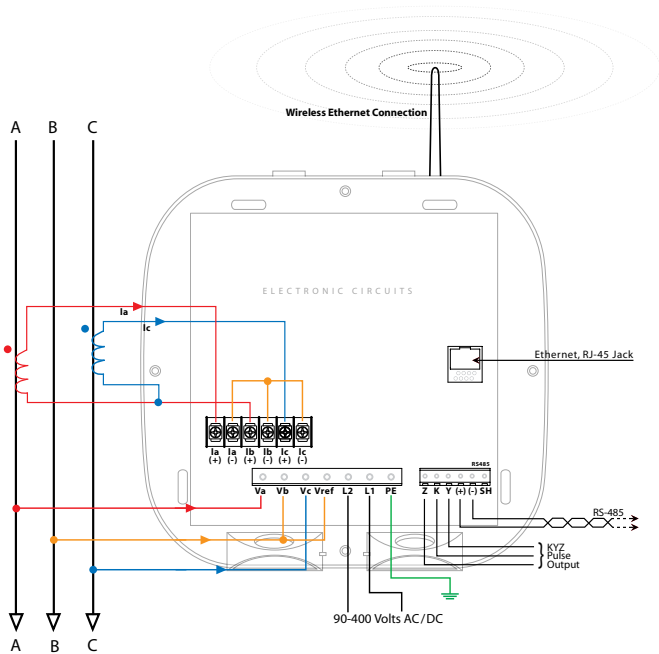

3 Phase 3 Wire Delta Direct

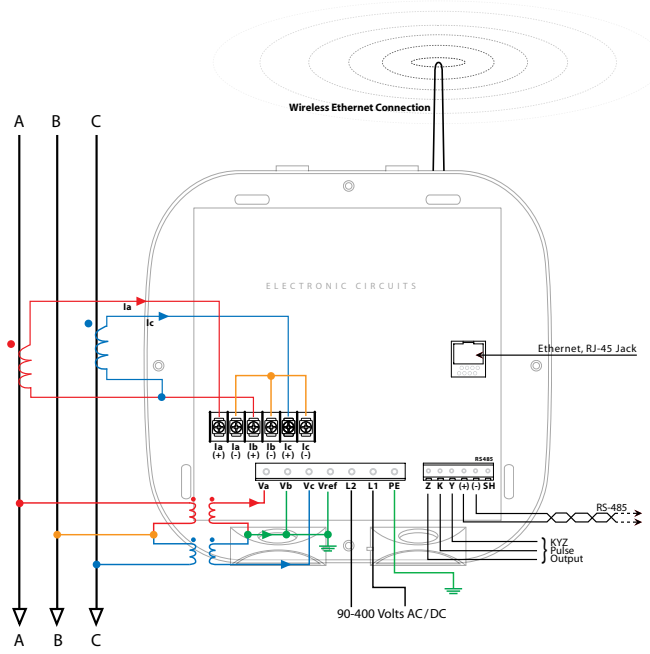

3 Phase 3 Wire Delta with PTS

Specifications

Voltage Inputs

- 20-416 Volts Line To Neutral, (Shark® 100-S meter), 20-576 Volts Line to Neutral (Shark® 200-S meter)
- 0-721 Volts Line to Line
- Universal Voltage Input
- Input Withstand Capability – Meets IEEE C37.90.1 (Surge Withstand Capability)
- Programmable Voltage Range to Any PT ratio
- Supports: 3 Element WYE, 2.5 Element WYE, 2 Element Delta, 4 Wire Delta Systems
- Burden: 0.36VA per phase Max at 600V, 0.014VA at 120 Volts

Current Inputs

- Class 10: 5 Amp Nominal, 10 Amp Maximum
- Class 2: 1 Amp Nominal, 2 Amp Secondary
- Programmable Current to Any CT Ratio
- Burden 0.005VA per phase Max at 11Amps

- 5mA Pickup Current for Class 10
- 1mA Pickup Current for Class 2
- Current Surge Withstand: 100A/10 Seconds at 23° C

Isolation

All Inputs and Outputs are galvanically isolated to 2500 Volts AC.

Environmental Rating

- Storage: (-20 to +70)° C
- Operating: (-20 to +70)° C
- Humidity: to 95% RH (Non-condensing)

Sensing Method

- RMS
- Sampling at 400+ Samples per Cycle on all channels measured readings simultaneously
- Harmonic %THD (% of Total Harmonic Distortion) - Shark® 100-S meter only

Update Rate

- Watts, VAR and VA - Every 6 cycles (e.g., 100ms @ 60Hz)
- All other parameters - Every 60 cycles (e.g., 1s @ 60Hz) (1 second for Current Only measurement, if reference voltage is not available)

Power Supply

- (90 to 400) Volts AC and (100 to 370) Volts DC. Universal AC/DC Supply
- Burden: 16VA max.

Communication Format

- 2 Com Ports
- RS485 Port
- IrDA (Through Faceplate)
- Protocol Modbus RTU, Modbus ASCII
- Com Port Baud Rate: (9600 to 57,600)
- Com Port Address: 0-247
- 8 Bit, No parity
- Modbus RTU or ASCII Protocols

Ethernet

- 802.11b Wireless
- 10BaseT Ethernet (RJ45)
- Modbus TCP Protocol

Dimensions and Shipping

- Weight: 4 lbs
- 7.9H x 7.5W x 3.1D in 20.1H x 19.1W x 7.9D cm

Meter Accuracy

- See page 3

Compliance:

- IEC 687 (0.2% Accuracy)
- ANSI C12.20 (0.2% Accuracy)
- ANSI (IEEE) C37.90.1 Surge Withstand
- ANSI C62.41 – Burst
- IEC1000-4-2 – ESD
- IEC1000-4-3 – Radiated Immunity
- IEC 1000-4-4 – Fast Transient
- IEC 1000-4-5 – Surge Immunity
- UL Listed

Ordering Information

To order, please fill out ordering guide:

| | Model | Frequency | Current Class | V-Switch™ Pack | Communication Format |
|-----------------------|--------------|-----------------------|--------------------------|---|---|
| Option Numbers: | - | - | - | - | - |
| Example: Shark® 100-S | - | 60 | 10 | V3 | 485 |
| | Shark® 100-S | 50 50 Hz System | 10 5 Amp Secondary | V3* Default with Energy Counters (Shark® 100-S) | 485 RS485 |
| | Shark® 200-S | 60 60 Hz System | 2 1 Amp Secondary | V4* Above with Harmonics and Limits (Shark® 100-S) | WiFi Wireless or LAN Based Ethernet |
| | | | | V33** Multi-Function Meter with 2 MB Datalogging Memory (Shark® 200-S) | |

* Shark® 100-S meter only

** Shark® 200-S meter only

Additional Accessories

Communication Converters

CAB 6490 – USB to IrDA Adapter for Programming

Unicom 2500 – RS485 to RS232 Converter

Unicom 2500-F – RS485 to RS232 to Fiber Optic Converter

Modem Manager, Model #, MM1 – RS485 to RS232 Converter for Modem Communication

Compliance Documents

Certificate of Calibration, Part #: CCal – This provides Certificate of Calibration with NIST traceable Test Data.

Current Transformer Kits

CT200K – 200/5 Ratio 1.00" Window 3 CTs

CT400K – 400/5 Ratio, 1.25" Window, 3 CTs

CT800K – 800/5 Ratio, 2.06" Window, 3 CTs

CT2000K – 2000/5 Ratio, 3.00" Window, 3 CTs

CT Specifications:

Frequency: 50 to 400Hz; Insulation: 600 Volts, 10kV BIL

Flexible Leads: UL 1015 105°C, CSA Approved, 24" Long, #16AWG

Software Option Numbers

COMEXT3.1C – CommunicatorEXT 3.0 for Windows® (Single Lic)

COMEXT3.MC – CommunicatorEXT 3.0 for Windows® (Multi Lic)

* Consult factory application engineer for additional transformer ratios, types or window sizes.

E-Billing EXT™ – Automated bill generation software for Shark® 200-S Submeter only.



Electro Industries/GaugeTech

1800 Shames Drive • Westbury, NY 11590

1-877-EIMETER (1-877-346-3837) • E-Mail: sales@electroind.com

Tel: 516-334-0870 • Web Site: www.electroind.com • Fax: 516-338-4741